

# MDSI Perimeter Extrusion Series 30

## Installation Guidelines



**METAL  
DESIGN  
SYSTEMS**

---

**DESIGNED FOR  
A PERFECT FIT.**

---

Metal Design Systems is pleased to offer an Installer's EDGE training course at our home office in Cedar Rapids, Iowa. This class is offered once a month, free of charge to the installer. If you are interested in attending, please contact MDSI via email at [tech@crmdsi.com](mailto:tech@crmdsi.com).

# Metal Design Systems, Inc.

## SERIES 30

### Installation Guidelines

#### Required Equipment:

##### Forklift:

Typically crates are shipped directly to the job site from our fabrication facility via LTL carrier. This means the crates will arrive in an enclosed trailer which will require either a dock and a fork lift, or an extended reach forklift in order to unload the crates. The average crate size is 4' x 10', but they can be up to 5' x 16'. Large shipments can be delivered on flat bed trucks if prior arrangements are made.

##### Man-lift/Scaffolding/Ladders:

The terrain, accessibility, quantity of work on each area, and height of work will typically determine the type of lift equipment required to complete each project. The preferred option will usually be an all terrain scissor lift because they offer a larger platform allowing for more work space and fewer moves.

##### Work Table:

You will need a work surface to prep the panels for installation, cut penetrations, or make field modifications. The table should be large enough to safely support the largest panels on the project, and be covered with a long pile carpet to protect the panels from damage. Some installers prefer to build tables on site using the crating materials. This is perfectly acceptable provided that they are constructed in a sturdy fashion.

##### Power Tools:

10" or 12" miter saw with 80 tooth non-ferrous metal cutting blade for cutting extrusions; jig saw with plywood cutting blade for cutting penetrations in panels; router with carbide tipped, flat point V-bit; drill and various sized drill bits; screw gun with 5/16" hex head driver and #2 Phillips bit.

##### Hand Tools:

Pop-Rivet gun, rubber mallet, single-cut metal file, countersink bit, hole saw kit for penetrations, caulk gun, utility knife, single edge razor blades, tin snips, flat blade screw driver, tape measure, 4 foot level, torpedo level, (a laser or sight level can be very helpful for layout depending upon the complexity of the project), chalk line, safety glasses, work gloves, and hearing protection.

##### Supplies:

Always have an ample supply of fasteners in various sizes; plastic horseshoe shims in 1/4", 1/8", and 1/16" thicknesses; silicone sealant in the appropriate color; waterproof tarps to cover the crates; and shop rags.

##### Crew Size:

A crew size of three typically works best in most cases. This allows for two in the lift, handling and installing the panels on the wall; and one on the ground prepping panels, cutting and drilling extrusions, and for general ground support.

##### Unloading:

Prior to unloading the crates from the delivery truck inspect the crates for damage.

**Note: Report any damage to the carrier and note the damage on the shipping tickets. The receiver must make all claims for damage through the carrier upon receipt. Metal Design Systems, Inc. is not responsible for any damage after the product leaves the factory.**

Unload the material one crate at a time, know and follow all safety rules. Use the proper equipment for the weight being unloaded. If unloading with an overhead crane, use a spreader bar and nylon slings, do not "choke" the crates. Do not attempt to lift the crates by hand, drag, drop, or stack the crates.

### Inspection and Inventory:

Shipping damage should be noted on the Bill of Lading and then reported to Metal Design Systems, Inc.

**Note: The customer is responsible for filing a claim for freight damage with the shipping company within 24 hours of receipt. Failure to do so may result in forfeiture of the right to receive corrective action.**

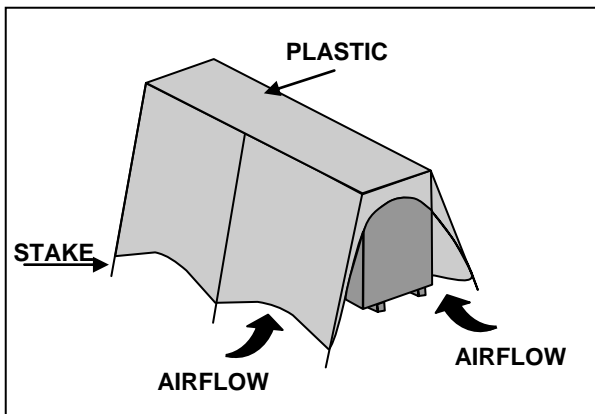
After verifying the condition of the product, inventory the panels and miscellaneous items and compare against the packing slip to ensure that all material is received.

**Note: Notify Metal Design Systems, Inc. immediately if the quantities received do not match the packing list. Failure to do so may result in forfeiture of the right to receive corrective action.**

### Storage:

Store crates in a clean dry place. If the crates are to be stored outside, cover the crates to protect from the elements and ventilate to minimize heat build up (Figure 1). At the end of each work day, place loose panels back into the open crates, secure the panels, and cover the crate.

Figure 1



### Shake Out:

Crate #1 will have a set of shop drawings revised to reflect field measurements and indicating panel part numbers and locations.

Each crate will have a packing slip indicating the part numbers and quantities of the panels enclosed. At this time it may be beneficial to boldly write the contents of each crate on the outside for future reference. If possible, strategically place each crate in a location convenient to the final destination of its contents.

### Handling Individual Panels:

When removing panels from the crate, always take care to lift and clear other panels and sidewalls of the crate (Figure 2). Never slide or drag panels out of their location. When carrying the panels, always carry it “on edge” and never flat (Figure 3). Always be aware of your surroundings and take special care when handling panels that have intermediate routs or panels that have welded connections. Do not place the panels in any position that will cause the panel face or edges to come into contact with any surface that will cause damage to the protective film or panel finish. The protective film is designed to prevent minor abrasions. Extreme care should still be taken to avoid dents and scratches.

Figure 2

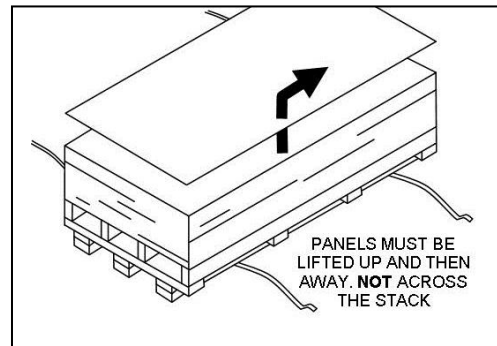
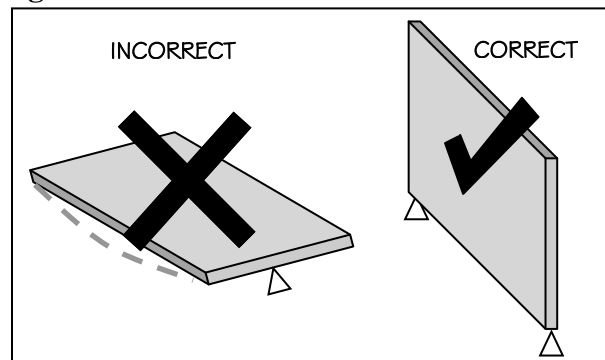


Figure 3



### Substrate/ Job Inspection:

Inspect the area that is to receive the panels to ensure that all work is complete and satisfactory. All substrates, weather barriers, penetrations, doors, windows, and any other adjacent materials should be in place and cleaned prior to proceeding with panel installation.

**Note: Acid wash used for cleaning masonry will cause permanent damage to the panels.**

Ensure that all surfaces are plumb, level, square, true, dry, and free from defects. Do not begin installation until all unsatisfactory conditions have been corrected.

### Installing Flashing and Weather Barrier:

Install flashing using standard sheet metal practices and procedures, ensuring that all joints and seams are weather lapped and sealed. For weather barrier, follow manufactures written instructions for proper installation. Integrate weather barrier and flashing to allow proper drainage of any moisture that may enter or accumulate within the panel system.

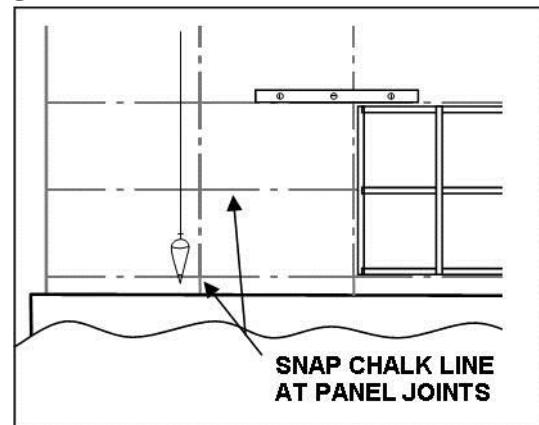
### Layout:

Reference the revised shop drawings and locate key components for panel system alignment (i.e. windows, doors, window mullions, or other items that are critical to joint locations) and begin layout from these locations. Snap chalk lines at the center of each panel joint making sure that all lines are level and plumb (**Figure 4**). This will help to control panel gain or loss over a long run. If the panel system is to be installed over a gypsum board substrate, locate all framing members to ensure that all fasteners engage a structurally sound member. Metal Design Systems, Inc. recommends a minimum #12, 300 series stainless steel self-tapping fasteners for applications into steel or aluminum and #12, 300 series stainless steel T17 point fasteners for wood substrates. The recommended maximum spacing is 16" on center. Please reference the project specific

details for fastener type and spacing requirements.

If the system is applied over a gypsum sheathing substrate, ensure that the fasteners are of sufficient length to properly engage the structural framing members. Self-drilling/self-tapping fasteners require a minimum of 3 fully formed threads extending beyond the back of the metal, and wood screws require a minimum of 1" penetration

**Figure 4**



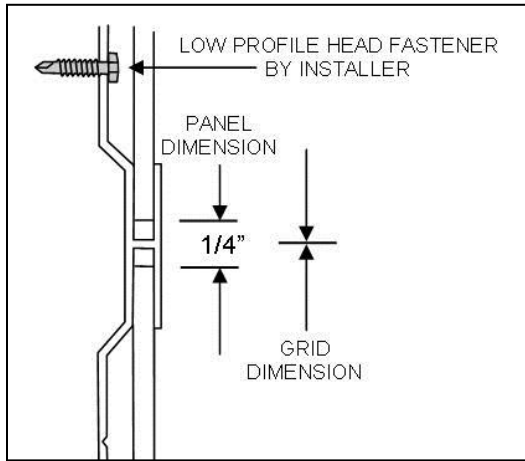
### Installing Panels Metal Design Systems Series 30:

#### General:

Locate work table and miter saw in a safe and convenient location relative to the installation area. The panels must be cut to a size smaller than the nominal joint to joint dimension of the panel grid. This will typically be 1/4" smaller than the nominal dimension in both the X and Y directions. This is to allow some tolerance as well as thermal expansion of the panels.

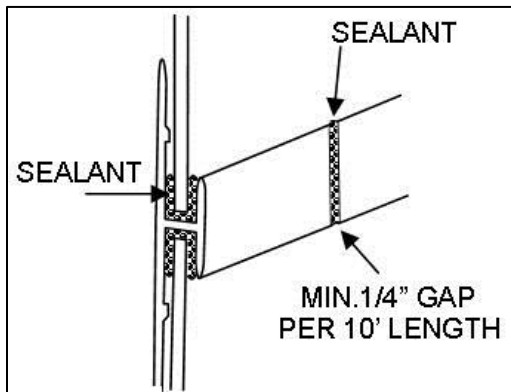
(**Figure 5**)

**Figure 5**



All intersections and splices of the aluminum extrusions shall be gapped and caulked to allow for thermal expansion. This shall be based upon a minimum of 1/4" gap per 10 lineal feet. (Figure 6) Failure to gap the extrusions and panels will result in extrusion buckling and potential system failure.

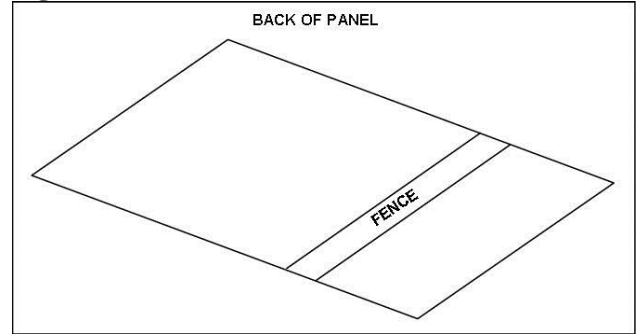
**Figure 6**



**Field Cutting Panels:**

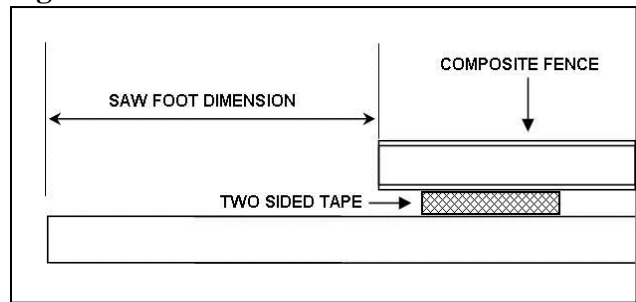
Determine the required nominal dimension of the panel according to the layout and subtract the required distances for clearance and thermal expansion. Cut the panel using a circular saw with a fine tooth carbon tipped blade (Figure 7).

**Figure 7**



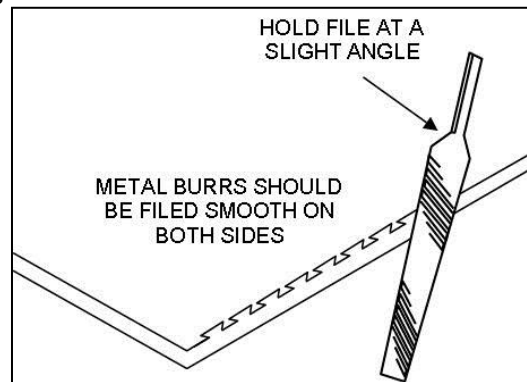
Two sided tape works well to temporarily secure the fence to back of the panel (Figure 8).

**Figure 8**



After cutting the panel, file the edges smooth. This will ensure a proper fit in the extrusions and could prevent personal injury (Figure 9).

**Figure 9**

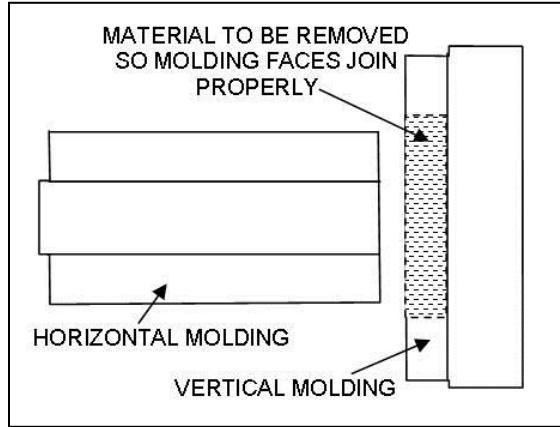


**Cutting & Fitting Extrusions:**

The appearance, quality and soundness of the panel system depend in large part upon the quality and fit of the trim extrusions. For accurate cutting, a miter saw with carbide tipped blade is recommended to cut the extrusions to length. Notching of extrusions may also be required for some intersections.

Metal snips and/or a miter saw may be used to remove portions of the extrusion so the intersection can fit together properly (**Figure 10**).

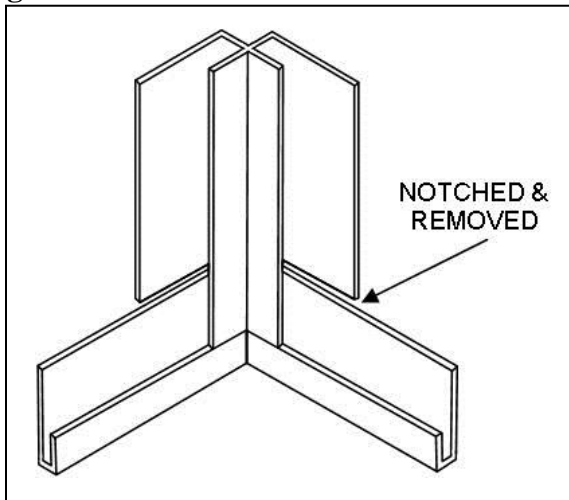
**Figure 10**



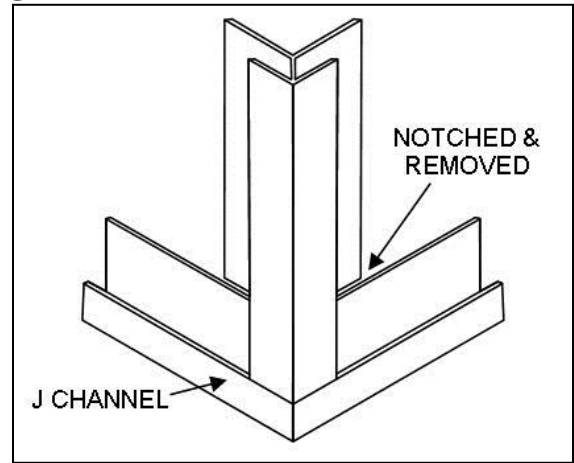
**NOTE:** Whenever cutting, trimming or installing moldings, it is important to make sure the joints are well fitted and the intersections formed provide a clean channel into which the panel can be placed.

**Typical Trim Intersections & Notching:**

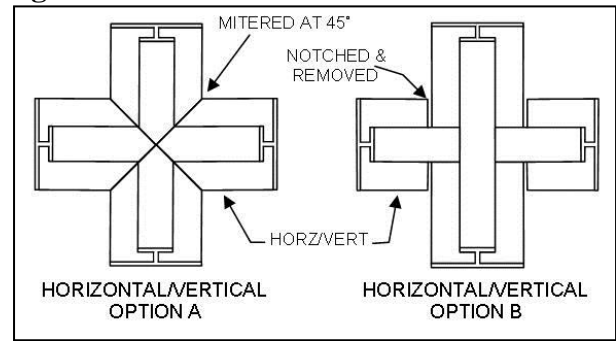
**Figure 11**



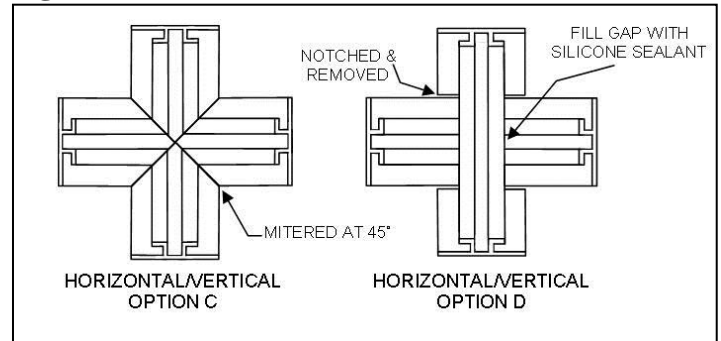
**Figure 12**



**Figure 13**

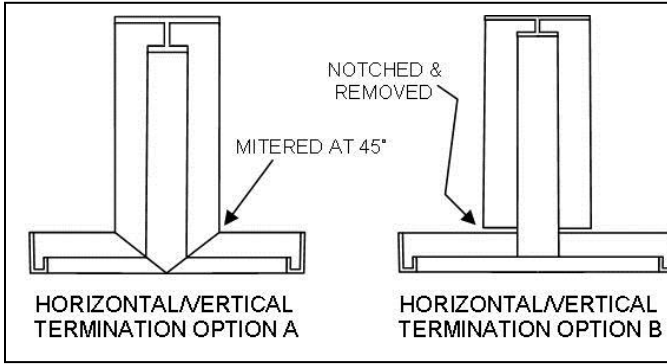


**Figure 14**

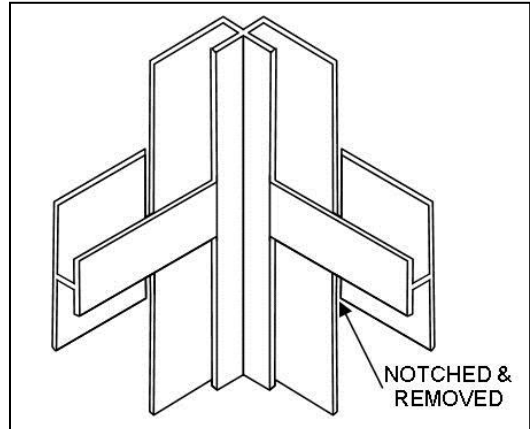




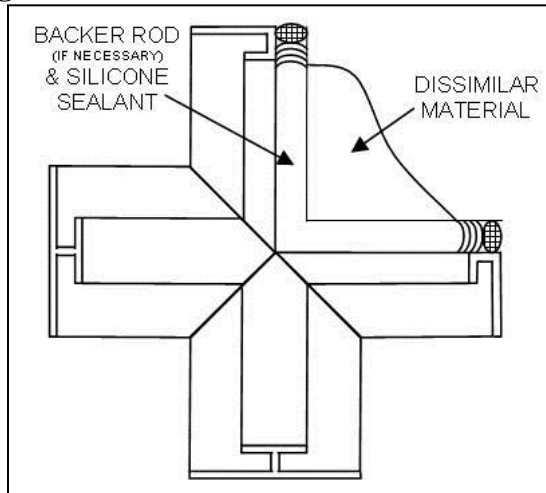
**Figure 15**



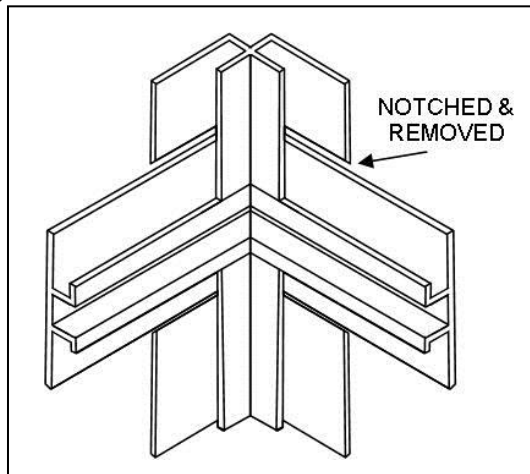
**Figure 18**



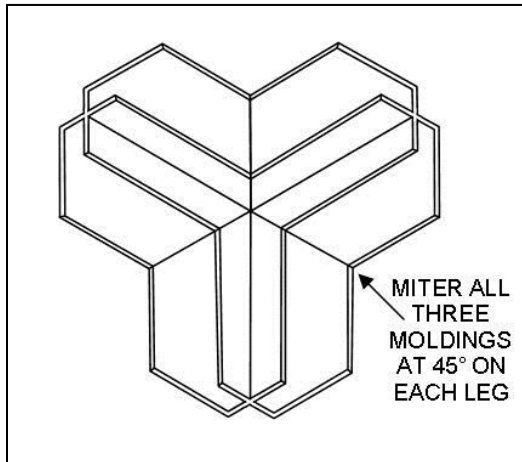
**Figure 16**



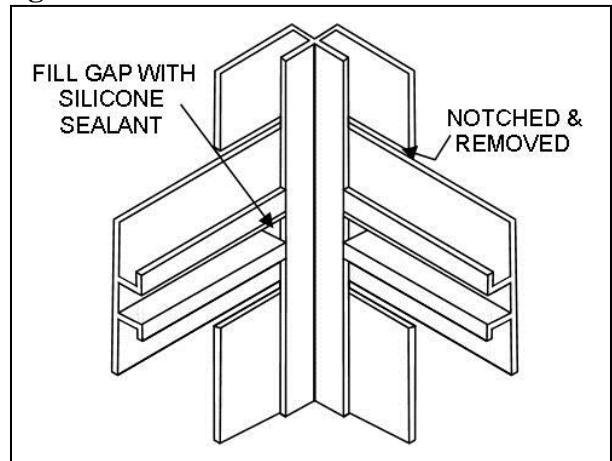
**Figure 19**



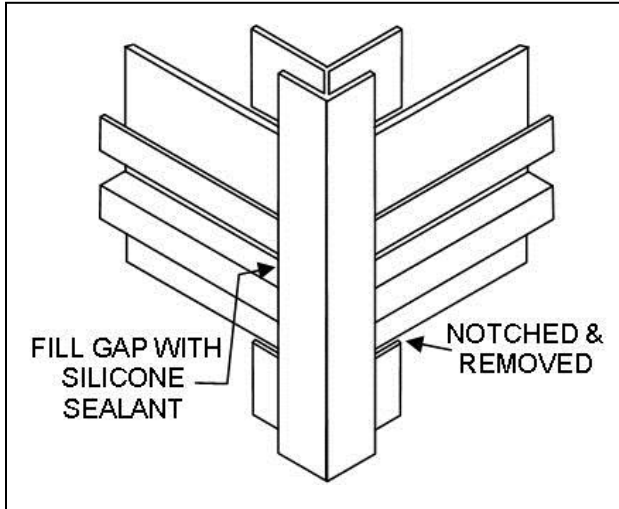
**Figure 17**



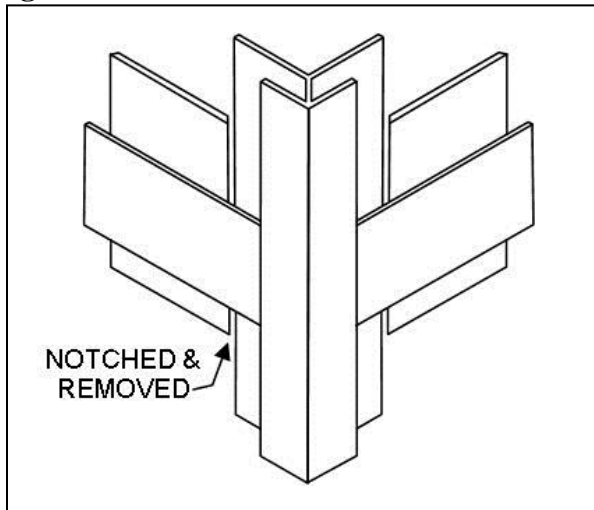
**Figure 20**



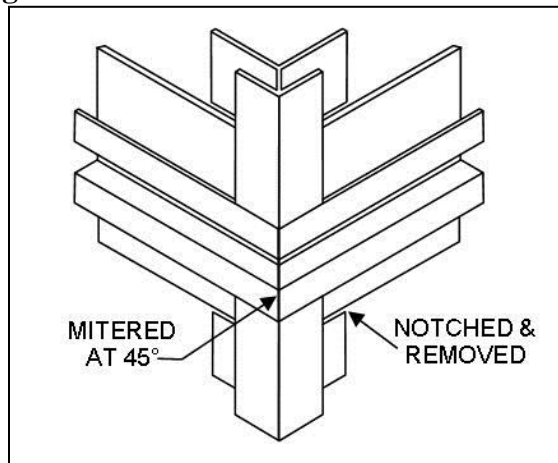
**Figure 21**



**Figure 22**



**Figure 23**

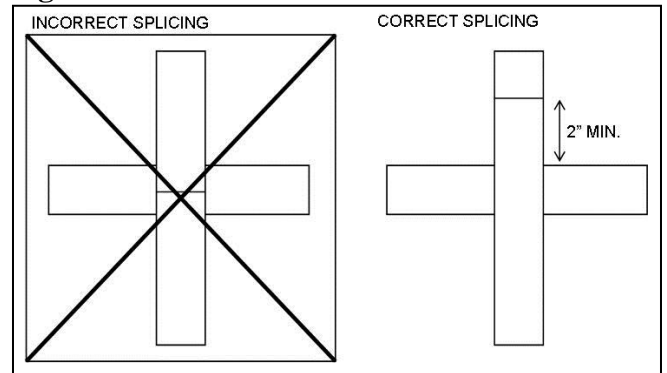


**Splicing of Extrusions:**

Depending on grid size, several lengths of extrusions may be required to complete a horizontal and/or vertical run. Planning should be done to minimize the number of splices required.

**NOTE: When necessary, splices must occur no closer than 2" away from the horizontal/vertical intersection (Figure 24) Splices must be completely sealed against moisture. 2" rule does not apply if the molding intersections are being mitered, however all intersection must still be sealed.**

**Figure 24**



**General Work:**

**Proper Sealant Application:**

The exterior cladding system is designed to keep water away from the structural wall system. Therefore, it is imperative that the following guidelines be followed accurately to ensure the integrity of the system against moisture intrusion.

**NOTE: Failure to adequately seal ALL panel edges, molding intersections and splices, cutouts, etc., will cause direct water infiltration.**

**Selecting the Right Sealant:**

In order for the proper bond to be created between the sealant and the system components, be sure to use only the sealant recommended by the manufacturer.

The use of other sealants may require additional steps (such as priming of materials) or cause the



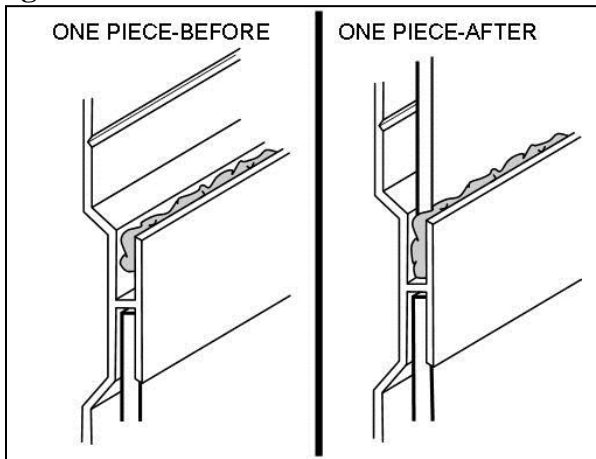
installation to fail due to poor weather ability, staining and/or lack of adequate bonding.

**Sealant Application:**

In general, sealant should be liberally applied wherever water may be able to infiltrate the system (e.g. joints, molding splices, dissimilar material abutments, etc.).

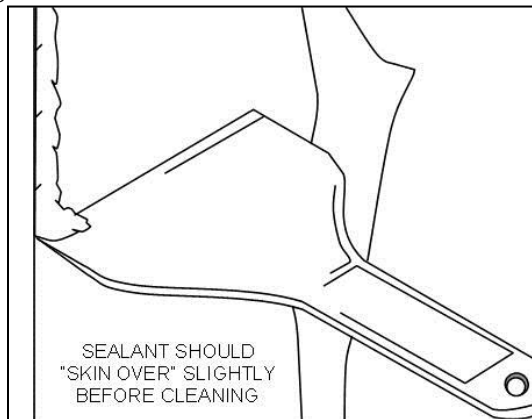
For the one piece system, the sealant should fill enough of the molding channel (**Figure 25**) so that squeeze out will occur when the panel is inserted.

**Figure 25**



Excess sealant may be cleaned up (**Figure 26**) after it ‘skins over’ (approx. 45 minutes) using a non-marring scraper, a clean rag and mineral spirits (if necessary).

**Figure 26**



When abutting dissimilar material (i.e. glazing, brick, etc.), allowances must be made for expansion/contraction (min. 1/4”). Bond breaker tape should be applied to the sheathing prior to the application of the receiver and an approved sealant applied after the panel and aluminum cover are installed.

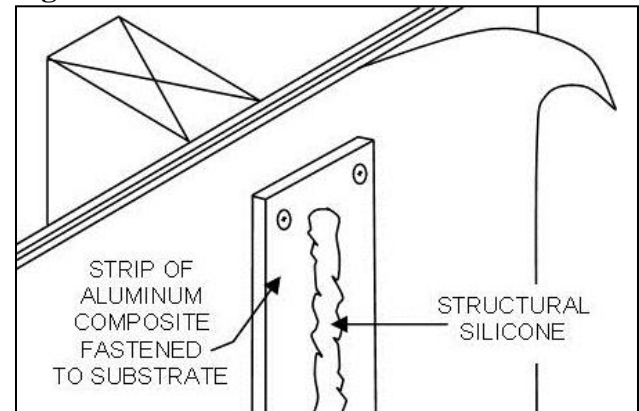
**Proper Adhesive Application:**

Depending upon the panel size, an adhesive may be required in the field of the panel. Structural silicone may be used to adhere the panel to the substrate.

In general, a bead (or strip) of structural silicone must be placed at each intermediate location within the field of the panel (16”-24” o.c.). The approximate size of the bead should be 3/8” diameter (min.) x 2/3 of the panel height. However, due to the design of the molding, the panels are held away from the substrate by approximately 3/16”. Therefore, the substrate must be shimmed out (using scrap pieces of panel) in order for the structural silicone to bond properly with the back of the panel. The structural silicone is then applied to the shim (or panel scrap).

Apply strips of 4mm aluminum composite (approx. 2”-3” wide x 2/3 panel height) which must be mechanically fastened to the substrate. (**Figure 27**) Structural silicone is then applied to the aluminum composite strip.

**Figure 27**



**Installing Panels:**

**Attaching the Bottom Horizontal & Left Vertical Moldings:**

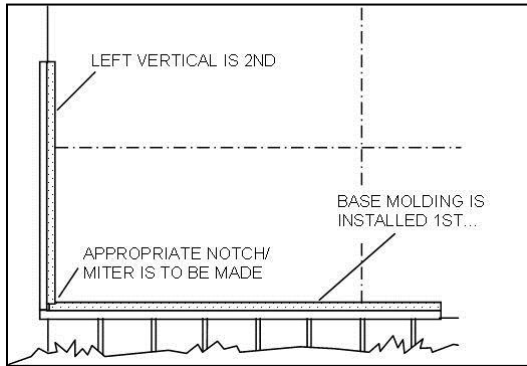
Since the installation is progressive, the panel is encapsulated on all four sides by the one piece moldings. Therefore, the first step in the work sequence is creating an 'L' shaped pocket into which the panel will be placed.

In order to move the installation up, then across the elevation, the first two moldings to be attached at the bottom horizontal and the left vertical (**Figure 28**).

Miter or notch the moldings as needed and then fasten them to the substrate. Keep in mind that verticals 'pass through' horizontals except at head and sill locations.

The required molding length will vary dependent upon condition and grid layout.

**Figure 28**



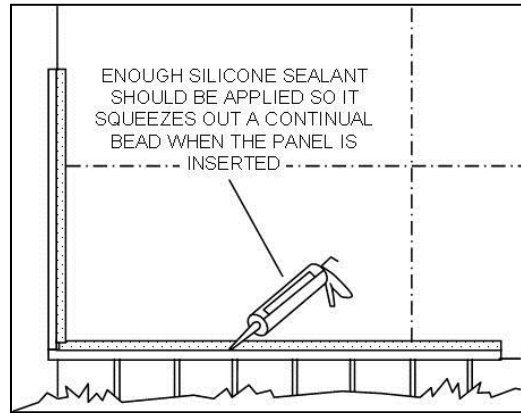
**Preparing the Panel & Applying the Sealant:**

Begin by cutting the panel to the proper dimension with allowance made for expansion/contraction. Peel the protective film away from all four edges of the panel. Do not remove it completely.

**NOTE: Failure to adequately seal ALL panel edges will cause the installation to fail.**

Place a large, continuous bead of approved sealant into both the bottom horizontal and left vertical moldings (**Figure 29**). If the moldings extend past the first panel length/width, apply only enough sealant for one panel.

**Figure 29**

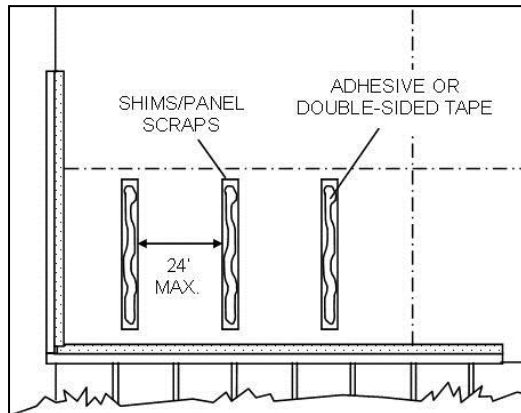


**Applying the Panel Adhesive**

Begin by fastening the appropriate shims (panel scraps) to the substrate at the intermediate locations (shimming reduces the gap between panel and the substrate created by the molding offset). Then, place a large bead of panel adhesive onto each shim (**Figure 30**).

**NOTE: The adhesive bead should not be allowed to set up before the panel is applied.**

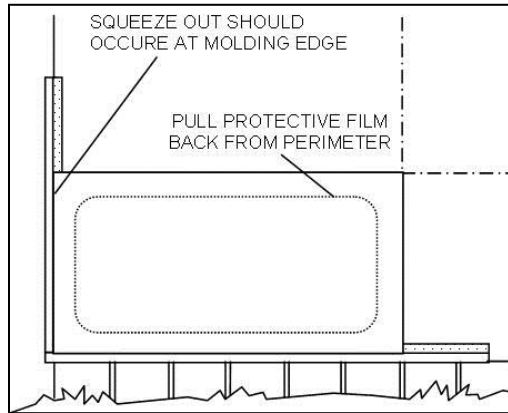
**Figure 30**



**Inserting Panel into Molding Channels:**

Insert the panel into the moldings (a non-marring scraper may assist in guiding the panel into the channel). If the correct amount of sealant is applied, it should squeeze (**Figure 31**) from the molding in a continual bead around the panel perimeter. The excess will be removed in a later step.

**Figure 31**

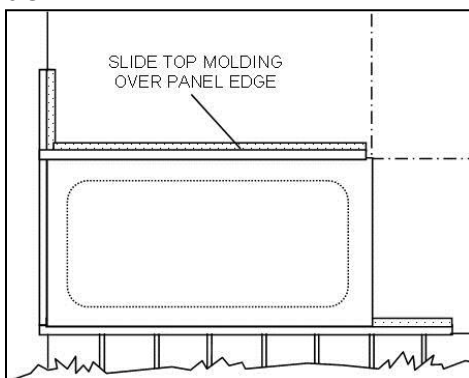


**Attaching Top Horizontal Molding:**

Since verticals typically dominate, the top horizontal molding should be notched/mitered to ‘dive into’ the left vertical molding. Likewise, the other end of the molding should be notched/mitered after being cut to length to receive the right vertical molding to be attached next.

After the molding has been prepared, apply the proper amount of sealant into the channel (only the side facing the panel) and place it over the edge (**Figure 32**). As in the previous step, sealant squeeze out should occur. Fasten the top molding to the substrate.

**Figure 32**



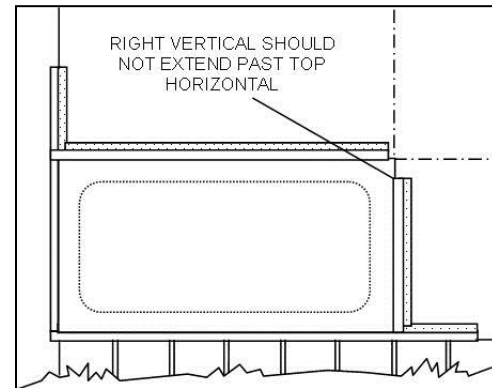
**Attaching Right Vertical Molding:**

After preparing (cutting, applying sealant), the right vertical should be fastened to the substrate (**Figure 33**).

**NOTE: The final molding in the sequence (right vertical) should never extend past the top horizontal (Figure 33). Thus creating a ‘U’ shaped channel and prevent the next**

**panel in the vertical sequence from being installed properly.**

**Figure 33**

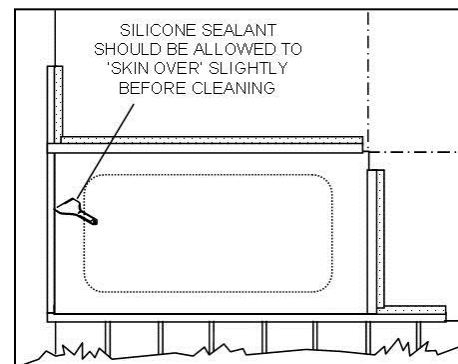


**Cleaning Excess Sealant & Removing Protective Film:**

Once the fastening is complete, the excess sealant can be cleaned from the panel surface using a non-marring scraper, clean rag and mineral spirits (if necessary).

The scraper should be held at a low angle (**Figure 34**) and run along the perimeter of the panel using the molding as a guide. Once complete, remove the protective film by pulling it back against itself along the panel.

**Figure 34**



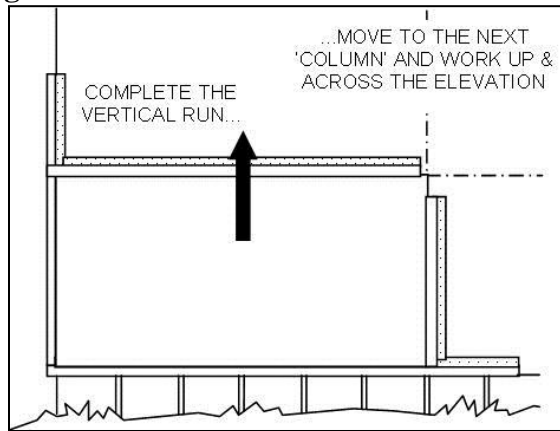
**Moving Up & Across the Elevation:**

Once the first panel is installed, repeat the work sequence and move vertically in the grid. Upon completion of the first column, move again to the bottom of the elevation and begin at the next column.

Each individual application may vary depending upon layout. However, moving vertically across the elevation requires the least amount of set-up

and may prove the most efficient use of scaffolding and/or power lifts (**Figure 35**).

**Figure 35**



### **Cleaning Panels:**

In most cases, never use anything more than mild detergent and a soft cloth to clean the panels. Rinse with clean water immediately afterwards. See panel manufacturer's recommendations for proper cleaning methods.

### **Clean Up:**

Keep work areas free of objects that could cause injury or damage to the panels. At the end of each work day, place all trash and debris into the appropriate containers for disposal.

**These guidelines are intended to convey the general sequences and procedures. Each application may vary and require specialized procedures. Refer to the project specific details for specialized instruction or contact Metal Design Systems, Inc. Phone: 319-362-7454**

**Revised 5/27/15**